

2016

indiana line





Indiana Line is a brand of  
Coral Electronic srl  
10098 Rivoli - Torino - Italy  
corso Allamano 74  
info@coralelectronic.com  
www.indianaline.it

2016

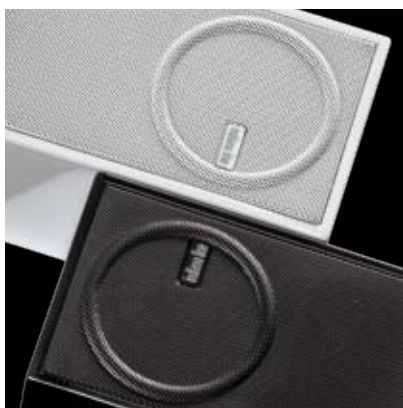

INDIANA LINE NASCE A TORINO NEL 1977.  
La realizzazione di componenti hi-fi, dai contenuti autentici e razionali, è sempre stata la filosofia della nostra azienda: naturalmente aperti all'innovazione, abbiamo più volte sviluppato progetti originali, rifiutandoci di seguire le mode.

*INDIANA LINE WAS FOUNDED IN TURIN IN 1977.  
Since the early years we have stayed true to our philosophy: the creation of hi-fi units with authentic and rational contents. Naturally open to innovation, we have repeatedly developed original projects, refusing to follow trends.*

indiana line

Nel disegnare i modelli Puro, non abbiamo mai cercato soluzioni per impressionare al momento, ma eleganti forme senza tempo: sono prodotti fatti per offrire il massimo delle prestazioni per decenni. Gli amplificatori ed il lettore di compact disc Puro sono caratterizzati dall'invidiabile neutralità timbrica e dalla naturalezza nella riproduzione delle voci, con una capacità dinamica che va ben oltre le loro caratteristiche nominali.

*By designing the models Puro, we have never looked for solutions to impress at the moment, but for elegant and timeless shapes: our products are made to offer the highest performance for decades. Puro amplifiers and compact disc player are characterized by excellent tonal neutrality and voice naturalness, with a dynamic capability that goes far beyond their nominal data.*

## PURO





## PURO CDP

frequency response	20 ÷ 20000 Hz +/- 0.5 dB
THD	0.002% @ 1 kHz
digital/analog converter	24 bit / 192 kHz
signal noise ratio	> 110 dB A weighted
channel separation	> 102 dB @ 1 kHz
dynamic range	> 95 dB

analogic output	2.2 Vrms / 100 ohm
coaxial digital output	500 mVpp / 75 ohm
optical digital output	JEITA CP-1212

power supply	220 ÷ 240 VAC / 50 Hz
power consumption	30 W max
dimensions	430 x 88 x 325 mm
weight	5.6 kg
remote control	included



## PURO

type	remote control
batteries	infrared
dimensions	2 x AAA (1.5 V)
weight	45 x 206 x 19 mm
	150 g

All'interno dei loro solidi telai, i modelli Puro custodiscono circuiti stampati a doppia faccia con fori metallizzati, sui quali sono montati componenti selezionati tra cui il generoso trasformatore toroidale e l'affidabile meccanica del lettore CD, adeguatamente protetto da uno schermo metallico. Il layout è stato studiato nei più piccoli dettagli, per garantire il percorso più breve possibile del segnale. Entrambi gli amplificatori sono dotati di ingresso phono MM e di by-pass, per collegare il mondo degli audiofili con quello home cinema; per il collegamento veloce di una sorgente portatile, troviamo una presa mini-jack sul pannello frontale. Inoltre, Puro 800 è dotato di un convertitore DAC interno di elevata qualità e di tre ingressi digitali: coassiale, ottico e USB. L'uso degli apparecchi è facile ed intuitivo, nonostante la completezza delle loro funzioni.



## PURO 800

power (THD 0,1%)

frequency response

THD

signal noise ratio

input sensitivity

pre output

digital/analog converter

power supply

power consumption

dimensions

weight

remote control

DAC stereo integrated amplifier

80 watt rms / 2 channel driven (8 ohm)

110 watt rms / 2 channel driven (4 ohm)

10 ÷ 80000 Hz +/- 0.5 dB

20 ÷ 20000 Hz +/- 0.5 dB (Phono)

0.006% @ 1 kHz (80% nominal power)

> 92 dB A weighted (CD, Aux)

> 82 dB A weighted (MM Phono)

400 mV / 47 kohm

1.2 mV (MM Phono)

750 mV / 600 ohm

24 bit / 192 kHz

500 mVpp / 75 ohm coaxial input

JEITA CP-1212 optical input

32 ÷ 96 kHz USB input sampling rate

220 ÷ 240 VAC / 50 Hz

280 W max

430 x 88 x 345 mm

8.2 kg

included



Inside the solid chassis, the Puro models preserve double-sided printed circuit boards with through plated holes, on which selected components are mounted as the generous toroidal transformer and the reliable CD player mechanics, adequately protected by a metal shield. The layout has been designed in the smallest details to ensure the shortest possible signal paths. Both amplifiers feature MM phono input and by-pass, to link the world of audiophiles with the home cinema; for fast connection to a portable source, we find a mini-jack input on the front panel. Furthermore, Puro 800 is equipped with a high-quality internal D/A converter and three digital inputs: coaxial, optical and USB. The use of equipment is easy and instinctive, despite the completeness of their functions.



<b>PURO 500</b>	stereo integrated amplifier
power (THD 0,1%)	50 watt rms / 2 channel driven (8 ohm) 75 watt rms / 2 channel driven (4 ohm)
frequency response	10 ÷ 80000 Hz +/- 0.5 dB 20 ÷ 20000 Hz +/- 0.5 dB (Phono)
THD	0.01% @ 1 kHz (80% nominal power)
signal noise ratio	> 90 dB A weighted (CD, Aux) > 81 dB A weighted (MM Phono)
input sensitivity	400 mV / 47 kohm 1.2 mV (MM Phono)
pre output	750 mV / 600 ohm
power supply	220 ÷ 240 VAC / 50 Hz
power consumption	190 W max
dimensions	430 x 88 x 345 mm
weight	7.2 kg
remote control	included

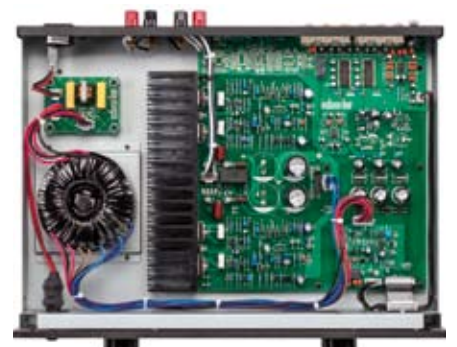

DIVA





I diffusori acustici della serie Diva garantiscono le prestazioni necessarie a soddisfare le esigenze di fedeltà, dinamica e tenuta in potenza richieste dalle più recenti tecniche di registrazione, per ricreare nel vostro ambiente d'ascolto le avvincenti emozioni di un concerto dal vivo o gli effetti speciali di un film d'azione. Ma sono soprattutto caratterizzati dalla invidiabile definizione e naturalezza nella riproduzione della voce.

*The Diva series loudspeakers warrant the performances needed to meet the musical quality precision, dynamic range and power handling capability required by the most advanced recording techniques, recreating in your listening room the engaging emotions of a live concert as well the special effects of an action movie. But they are mainly characterized by remarkable definition and naturalness in the voice reproduction.*



I tweeter Diva sono montati sul diffusore tramite un guscio di disaccoppiamento in gomma morbida, che rende virtualmente "flottante" il componente: si ottiene così una sensibile riduzione delle vibrazioni trasmesse dal mobile al tweeter stesso. La corretta escursione della cupola è controllata da una camera di risonanza radiale, provvista di due diversi tipi di assorbitore acustico, inseriti sotto la cupola ed all'interno dell'anello di ventilazione.

*Diva tweeter is uncoupled from the enclosure through a soft rubber shell, which makes it a virtually "floating" component: in this way we obtain an important reduction of the vibrations sent from the cabinet to the tweeter. The proper excursion of the dome is controlled by a radial resonance chamber, provided with two different types of acoustic damper, placed under the dome and inside the venting ring.*

Per i coni dei mid-woofer abbiamo scelto il Curv: un materiale rigido, leggero e smorzato, realizzato con puro polipropilene estruso, tessuto e trattato termicamente. Il complesso magnetico è dotato di Aluring: un anello di corto circuito che riduce la non linearità tipica dei sistemi tradizionali, aumentando l'escursione controllata della bobina mobile.

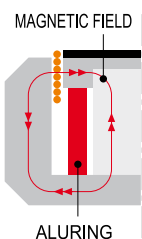

*For the mid-woofer cones we chose the Curv: a rigid, light and damped material, made with pure polypropylene extruded, woven and heat treated. Furthermore, we have equipped the magnetic circuit with Aluring: an aluminium short circuit ring that reduces the non-linearity, which affects all the commonly made magnet systems, increasing the voice coil controlled excursion capability.*





Il suono di Diva 665 è caratterizzato dalla risposta ai transienti veloce e molto precisa. Il tweeter "flottante" assicura alte frequenze naturali e dettagliate. Una coppia di woofer da 180 millimetri fornisce basse frequenze calde e corpose unite alla sorprendente capacità dinamica del diffusore.

Il corpo di Diva 665 è laccato nero high-gloss, mentre i fianchi sono impreziositi dai pannelli in vero legno di palissandro, rifiniti con cura artigianale.

*The sound of Diva 665 is characterized by the fast and very accurate transient response. The "floating" tweeter ensures natural and detailed high frequencies. A couple of 180 mm woofers provides warm and full bodied low frequencies combined with amazing dynamics.*

*The enclosure of Diva 665 is finished with a stylish black high-gloss lacquer, while the sides are enriched by the hand-crafted real rosewood panels.*

## DIVA 665

floor-standing loudspeaker

3-way, bass-reflex

30 ÷ 170 watt suggested amplifier

4 ÷ 8 ohm amplifier load impedance

35 ÷ 22000 hertz response

92 dB (2.83 V / 1 m) sensitivity

2 x 180 mm woofer

140 mm midrange

26 mm dome tweeter

300/2800 hertz crossover

187 x 950 x 300 mm - 19.8 kg

• bi-wiring / bi-amping terminals

• finishing: BLACK high gloss - ROSEWOOD

Numerosi pannelli di rinforzo, con sagomatura particolare, sono adeguatamente posizionati all'interno dei diffusori Diva per garantire sia la rigidità del mobile che l'abbattimento di eventuali onde stazionarie. Il volume delle colonne è diviso in due sezioni: la parte alta è chiusa, per controllare l'escursione del midrange, mentre il volume inferiore è caricato con un condotto reflex a doppia svasatura, per fornire le massime prestazioni alle basse frequenze.

*Several peculiarly shaped internal reinforcement boards, are properly placed inside the Diva loudspeakers to ensure both the rigidity of the enclosure and the reduction of possible stationary waves. The tower volume is cut in two separate sections: the upper one is closed to control the midrange excursion while the second volume features a double flare vent to reach greatest performances at low frequencies.*



11



### DIVA 655

floor-standing loudspeaker  
 3-way, bass-reflex  
 30 ÷ 150 watt suggested amplifier  
 4 ÷ 8 ohm amplifier load impedance  
 38 ÷ 22000 hertz response  
 91 dB (2.83 V / 1 m) sensitivity  
 2 x 140 mm woofer  
 140 mm midrange  
 26 mm dome tweeter  
 300/2800 hertz crossover  
 162 x 900 x 270 mm - 14.8 kg

- *bi-wiring / bi-amping terminals*

• *finishing: BLACK high gloss - ROSEWOOD*



### DIVA 255

book-shelf loudspeaker  
 2-way, bass-reflex  
 30 ÷ 100 watt suggested amplifier  
 4 ÷ 8 ohm amplifier load impedance  
 48 ÷ 22000 hertz response  
 90 dB (2.83 V / 1 m) sensitivity  
 140 mm woofer  
 26 mm dome tweeter  
 2900 hertz crossover  
 162 x 280 x 275 mm - 5.6 kg

- *bi-wiring / bi-amping terminals*
- *foam plug supplied*

• *finishing: BLACK high gloss - ROSEWOOD*

12



### DIVA 552

floor-standing loudspeaker  
3-way, bass-reflex  
30 ÷ 130 watt suggested amplifier  
4 ÷ 8 ohm amplifier load impedance  
40 ÷ 22000 hertz response  
90 dB (2.83 V / 1 m) sensitivity  
140 mm woofer  
140 mm midrange  
26 mm dome tweeter  
300/2800 hertz crossover  
160 x 825 x 240 mm - 12.1 kg  
• *bi-wiring / bi-amping terminals*

• *finishing: BLACK high gloss*



### DIVA 262

book-shelf loudspeaker  
2-way, bass-reflex  
30 ÷ 120 watt suggested amplifier  
4 ÷ 8 ohm amplifier load impedance  
44 ÷ 22000 hertz response  
91 dB (2.83 V / 1 m) sensitivity  
173 mm woofer  
26 mm dome tweeter  
1900 hertz crossover  
200 x 400 x 310 mm - 8.7 kg  
• *bi-wiring / bi-amping terminals*

• *finishing: BLACK high gloss*

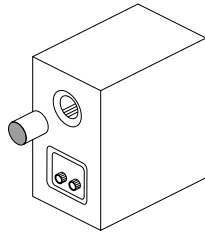

È possibile interfacciare il livello delle basse frequenze con le caratteristiche della stanza, semplicemente inserendo nel condotto reflex il tampone in dotazione a DIVA 255, 252 e 752.

*You can tune the low frequencies with the room acoustics, simply by fitting into the reflex vent the foam plug supplied with DIVA 255, 252 and 752.*

13



### DIVA 252

book-shelf loudspeaker  
 2-way, bass-reflex  
 30 ÷ 100 watt suggested amplifier  
 4 ÷ 8 ohm amplifier load impedance  
 48 ÷ 22000 hertz response  
 90 dB (2.83 V / 1 m) sensitivity  
 140 mm woofer  
 26 mm dome tweeter  
 2900 hertz crossover  
 160 x 280 x 275 mm - 5.3 kg

- *bi-wiring / bi-amping terminals*
- *foam plug supplied*

• *finishing: BLACK high gloss*



### DIVA 752

centre channel loudspeaker  
 2-way, bass-reflex  
 30 ÷ 140 watt suggested amplifier  
 4 ÷ 8 ohm amplifier load impedance  
 50 ÷ 22000 hertz response  
 91 dB (2.83 V / 1 m) sensitivity  
 2 x 140 mm woofer  
 26 mm dome tweeter  
 2200 hertz crossover  
 420 x 160 x 270 mm - 7.8 kg

- *foam plug supplied*

• *finishing: BLACK high gloss*

TESI



L'elevata definizione e naturalezza nella riproduzione delle voci, unite alla risposta ai transienti veloce e precisa, caratterizzano i diffusori della linea Tesi. La loro considerevole capacità dinamica si somma ai bassi caldi e corposi. I woofer utilizzano coni in polipropilene rinforzato con mica e rifasatori centrali per migliorare risposta e dispersione alle medie frequenze. I tweeter utilizzano cupole di seta molto leggera, potenti magneti al neodimio ed un'esclusiva camera di risonanza posteriore.

*The remarkable definition and naturalness in the voice reproduction, combined with fast and accurate transient response, characterize the Tesi line loudspeakers. Their considerable dynamic capability is added to the warm and full-bodied basses. The woofers feature special polypropylene cones stiffened with mica and central phase plugs, to improve response and dispersion at the medium frequencies. The tweeters use lightweight silk dome, powerful neodymium magnets and an exclusive rear chamber.*

15





## TESI 560

floor-standing loudspeaker  
 3-way, bass-reflex  
 30 ÷ 150 watt suggested amplifier  
 4 ÷ 8 ohm amplifier load impedance  
 35 ÷ 22000 hertz response  
 92 dB (2.83 V / 1 m) sensitivity  
 160 mm woofer  
 160 mm midrange  
 26 mm dome tweeter  
 180/2800 hertz crossover  
 175 x 890 x 310 mm - 13.6 kg  
 • *bi-wiring / bi-amping terminals*

• *finishing: CHERRY / DARK GREY OAK vinyl*



## TESI 260

book-shelf loudspeaker  
 2-way, bass-reflex  
 30 ÷ 120 watt suggested amplifier  
 4 ÷ 8 ohm amplifier load impedance  
 45 ÷ 22000 hertz response  
 91 dB (2.83 V / 1 m) sensitivity  
 160 mm woofer  
 26 mm dome tweeter  
 2500 hertz crossover  
 175 x 340 x 300 mm - 5.9 kg

• *finishing: CHERRY / DARK GREY OAK vinyl*



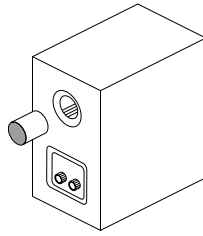

È possibile interfacciare il livello delle basse frequenze con le caratteristiche della stanza, inserendo nel condotto reflex il tampone in dotazione a TESI 240, 740 e 760.

*You can tune the low frequencies with the room acoustics, simply by fitting into the reflex vent the foam plug supplied with TESI 240, 740 and 760.*

17



fissaggio a parete  
*hangable on wall*



### TESI 240

book-shelf loudspeaker  
2-way, bass-reflex  
30 ÷ 80 watt suggested amplifier  
4 ÷ 8 ohm amplifier load impedance  
58 ÷ 22000 hertz response  
90 dB (2.83 V / 1 m) sensitivity  
120 mm woofer  
26 mm dome tweeter  
2700 hertz crossover  
135 x 230 x 195 mm - 2.5 kg

- foam plug supplied

• finishing: CHERRY / DARK GREY OAK vinyl



### TESI 740

centre channel loudspeaker  
2-way, bass-reflex  
30 ÷ 100 watt suggested amplifier  
4 ÷ 8 ohm amplifier load impedance  
55 ÷ 22000 hertz response  
92 dB (2.83 V / 1 m) sensitivity  
2 x 120 mm woofer  
26 mm dome tweeter  
2600 hertz crossover  
350 x 135 x 240 mm - 5.0 kg

- shielded loudspeakers
- foam plug supplied

• finishing: DARK GREY OAK vinyl



### TESI 760

centre channel loudspeaker  
2-way, bass-reflex  
30 ÷ 140 watt suggested amplifier  
4 ÷ 8 ohm amplifier load impedance  
45 ÷ 22000 hertz response  
93 dB (2.83 V / 1 m) sensitivity  
2 x 160 mm woofer  
26 mm dome tweeter  
2300 hertz crossover  
430 x 175 x 260 mm - 7.2 kg

- shielded loudspeakers
- foam plug supplied

• finishing: DARK GREY OAK vinyl



18



### TESI 542

floor-standing loudspeaker  
 3-way, bass-reflex  
 30 ÷ 120 watt suggested amplifier  
 4 ÷ 8 ohm amplifier load impedance  
 38 ÷ 22000 hertz response  
 91 dB (2.83 V / 1 m) sensitivity  
 120 mm woofer  
 120 mm midrange  
 26 mm dome tweeter  
 180/2700 hertz crossover  
 135 x 825 x 240 mm - 9.4 kg

- *bi-wiring / bi-amping terminals*

- *finishing: BLACK / WHITE high gloss*



### TESI 262

book-shelf loudspeaker  
 2-way, bass-reflex  
 30 ÷ 120 watt suggested amplifier  
 4 ÷ 8 ohm amplifier load impedance  
 45 ÷ 22000 hertz response  
 91 dB (2.83 V / 1 m) sensitivity  
 160 mm woofer  
 26 mm dome tweeter  
 2500 hertz crossover  
 175 x 340 x 300 mm - 5.9 kg

- *finishing: BLACK / WHITE high gloss*

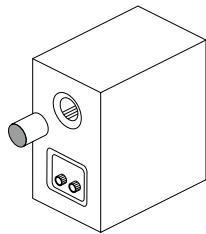

È possibile interfacciare il livello delle basse frequenze con le caratteristiche della stanza, inserendo nel condotto reflex il tampone in dotazione a TESI 242 e 742.

*You can tune the low frequencies with the room acoustics, simply by fitting into the reflex vent the foam plug supplied with TESI 242 and 742.*

19



fissaggio a parete  
*hangable on wall*



### TESI 242

book-shelf loudspeaker  
2-way, bass-reflex  
30 ÷ 80 watt suggested amplifier  
4 ÷ 8 ohm amplifier load impedance  
58 ÷ 22000 hertz response  
90 dB (2.83 V / 1 m) sensitivity  
120 mm woofer  
26 mm dome tweeter  
2700 hertz crossover  
135 x 230 x 195 mm - 2.5 kg

- foam plug supplied

• finishing: BLACK / WHITE high gloss



### TESI 742

centre channel loudspeaker  
2-way, bass-reflex  
30 ÷ 100 watt suggested amplifier  
4 ÷ 8 ohm amplifier load impedance  
55 ÷ 22000 hertz response  
92 dB (2.83 V / 1 m) sensitivity  
2 x 120 mm woofer  
26 mm dome tweeter  
2600 hertz crossover  
350 x 135 x 240 mm - 5.0 kg

- shielded loudspeakers
- foam plug supplied

• finishing: BLACK / WHITE high gloss

NOTA



I diffusori acustici della serie Nota garantiscono le prestazioni necessarie a soddisfare le esigenze di fedeltà, dinamica e tenuta in potenza richieste dalle più recenti tecniche di registrazione, per ricreare nel vostro ambiente d'ascolto le avvincenti emozioni di un concerto dal vivo o gli effetti speciali di un film d'azione. L'ottimizzazione del processo di produzione ed il perfetto equilibrio di tutti i componenti hanno permesso lo sviluppo di questa gamma dall'ottimo rapporto prezzo/prestazioni.

*The Nota series loudspeakers ensure the performances needed to meet the musical quality level, dynamic range and power handling capability required by the most advanced recording techniques, recreating in your listening room the engaging emotion of a live concert as well the special effects of an action movie. An optimized production process and a perfect blend of all the components brought to life this range of loudspeakers with a very good price/performance ratio.*





## NOTA 550

floor-standing loudspeaker  
 3-way, bass-reflex  
 30 ÷ 130 watt suggested amplifier  
 4 ÷ 8 ohm amplifier load impedance  
 38 ÷ 22000 hertz response  
 91 dB (2.83 V / 1 m) sensitivity  
 135 mm woofer  
 135 mm midrange  
 26 mm dome tweeter  
 250/2800 hertz crossover  
 175 x 880 x 275 mm - 11.4 kg

• finishing: CHERRY / DARK GREY OAK vinyl



## NOTA 260

book-shelf loudspeaker  
 2-way, bass-reflex  
 30 ÷ 100 watt suggested amplifier  
 4 ÷ 8 ohm amplifier load impedance  
 44 ÷ 22000 hertz response  
 92 dB (2.83 V / 1 m) sensitivity  
 166 mm woofer  
 26 mm dome tweeter  
 2600 hertz crossover  
 205 x 325 x 290 mm - 5.2 kg  
 • foam plug supplied

• finishing: CHERRY / DARK GREY OAK vinyl

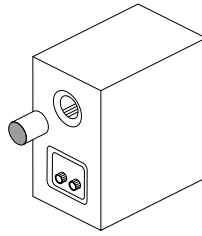

È possibile interfacciare il livello delle basse frequenze con le caratteristiche della stanza, inserendo nel condotto reflex il tampone in dotazione a NOTA 260, 250, 240 e 740.

*You can tune the low frequencies with the room acoustics, simply by fitting into the reflex vent the foam plug supplied with NOTA 260, 250, 240 and 740.*

23



fissaggio a parete  
*hangable on wall*



### NOTA 250

book-shelf loudspeaker  
2-way, bass-reflex  
30 ÷ 80 watt suggested amplifier  
4 ÷ 8 ohm amplifier load impedance  
48 ÷ 22000 hertz response  
90 dB (2.83 V / 1 m) sensitivity  
135 mm woofer  
26 mm dome tweeter  
2800 hertz crossover  
175 x 285 x 255 mm - 3.4 kg  
• *foam plug supplied*

• *finishing: CHERRY / DARK GREY OAK vinyl*



### NOTA 240

book-shelf loudspeaker  
2-way, bass-reflex  
30 ÷ 60 watt suggested amplifier  
4 ÷ 8 ohm amplifier load impedance  
54 ÷ 22000 hertz response  
89 dB (2.83 V / 1 m) sensitivity  
107 mm woofer  
26 mm dome tweeter  
3000 hertz crossover  
160 x 235 x 160 mm - 2.2 kg  
• *foam plug supplied*

• *finishing: CHERRY / DARK GREY OAK vinyl*



### NOTA 740

centre channel loudspeaker  
2-way, bass-reflex  
30 ÷ 100 watt suggested amplifier  
4 ÷ 8 ohm amplifier load impedance  
60 ÷ 22000 hertz response  
92 dB (2.83 V / 1 m) sensitivity  
2 x 107 mm woofer  
26 mm dome tweeter  
2600 hertz crossover  
400 x 130 x 235 mm - 4.6 kg  
• *shielded loudspeakers*  
• *foam plug supplied*

• *finishing: CHERRY / DARK GREY OAK vinyl*

DJ



DJ 308 e DJ 310 sono adatti alla riproduzione dei generi musicali più moderni: caratterizzati dall'elevata dinamica, sono il complemento ideale per le sorgenti digitali. Il particolare disegno della guida d'onda anteriore del tweeter domHorn fornisce l'ottima dispersione polare, insieme all'elevata efficienza. La camera di risonanza posteriore e la cupola in seta garantiscono la grande velocità dei transienti, la buona dinamica e le alte frequenze cristalline.

*DJ 308 and DJ 310 feature outstanding dynamics: the perfect match for digital sources. The design of the wave-guide front, exclusive of the domHorn tweeter, provides an excellent polar dispersion along with the high efficiency. The rear chamber and the treated silk dome warrant the speed transient and the crystal clear high frequencies.*



DOMHORN TWEETER





### DJ 308

book-shelf loudspeaker  
3-way, bass-reflex  
30 ÷ 140 watt suggested amplifier  
4 ÷ 8 ohm amplifier load impedance  
40 ÷ 22000 hertz response  
93 dB (2.83 V / 1 m) sensitivity  
230 mm woofer  
135 mm midrange  
26 mm dome tweeter  
500/3500 hertz crossover  
270 x 550 x 285 mm - 9.5 kg

- shielded loudspeakers

• finishing: BLACK ASH vinyl



### DJ 310

book-shelf loudspeaker  
3-way, bass-reflex  
30 ÷ 160 watt suggested amplifier  
4 ÷ 8 ohm amplifier load impedance  
38 ÷ 22000 hertz response  
94 dB (2.83 V / 1 m) sensitivity  
275 mm woofer  
135 mm midrange  
26 mm dome tweeter  
500/4000 hertz crossover  
320 x 620 x 295 mm - 14.1 kg

- shielded loudspeakers

• finishing: BLACK ASH vinyl

ZERO





27

Zero è un diffusore acustico dal design compatto e raffinato, che può essere utilizzato per realizzare piccoli impianti hi-fi stereo o sistemi home cinema. È molto adatto come canale surround per completare sistemi audio con importanti diffusori frontali. Fornisce un suono preciso, veloce e dettagliato, in cui la timbrica è equilibrata e le voci sono molto naturali. Zero utilizza un woofer da cento millimetri con cono in polipropilene rinforzato con mica ed un tweeter con cupola da 26 millimetri in seta impregnata; il crossover è realizzato con componenti di pregio.

*Zero is a very compact and stylish loudspeaker that can be used to build little hi-fi stereo or complete home cinema systems. It is suitable as surround speaker to complete audio systems using important front loudspeakers. It provides a very accurate sound, fast and detailed, the tone is balanced, the voices are very natural. Zero uses a one hundred millimetres woofer with polypropylene cone reinforced with mica and a tweeter with 26 mm impregnated silk dome; the crossover is made with good quality components.*



La staffa in dotazione permette il fissaggio a parete con diverse angolazioni.

*The supplied bracket allows the on-wall clamping with several angles.*



## ZERO

book-shelf loudspeaker  
2-way, bass-reflex  
20 ÷ 60 watt suggested amplifier  
4 ÷ 8 ohm amplifier load impedance  
60 ÷ 22000 hertz response  
89 dB (2.83 V / 1 m) sensitivity  
100 mm woofer  
26 mm dome tweeter  
3500 hertz crossover  
120 x 200 x 120 mm - 1.8 kg

• wall mounting bracket supplied

• finishing: BLACK / WHITE high gloss

I modelli Basso sono subwoofer attivi dal sorprendente impatto acustico, nati per completare l'estensione alle basse frequenze dei diffusori utilizzati negli impianti hi-fi e nei sistemi home cinema. I loro amplificatori sono dotati di una sezione controlli molto completa, che consente una perfetta interfaccia con gli altri componenti dell'impianto audio e con l'ambiente d'ascolto. Il design pulito e raffinato dei mobili e le compatte dimensioni rendono agevole il loro inserimento in ogni ambiente.

*Basso are active subwoofers with astonishing acoustic impact, they are suitable to complete the low frequency extension for stereo hi-fi or home cinema systems. Their amplifiers feature a very complete control section, which allows a perfect interface with the other components of the audio system and with the listening room. The clean and elegant design of the enclosures makes placement easy with any kind of furnishing.*

## BASSO





### BASSO 942

active subwoofer  
 220 mm speaker diameter  
 275 mm passive radiator  
 D-Class amplifier  
 250 watt nominal power  
 400 watt max power  
 25 ÷ 180 hertz frequency response  
 40 ÷ 180 hertz crossover frequency  
 220 ÷ 240 volt power supply  
 300 watt max power consumption  
 <0.5 watt stand-by consumption  
 310 x 335 x 345 mm - 13.7 kg

• finishing: *BLACK high gloss*

### BASSO 922

active subwoofer  
 275 mm speaker diameter  
 twin reflex port  
 AB-Class amplifier  
 75 watt nominal power  
 125 watt max power  
 29 ÷ 180 hertz frequency response  
 40 ÷ 180 hertz crossover frequency  
 220 ÷ 240 volt power supply  
 125 watt max power consumption  
 <0.5 watt stand-by consumption  
 310 x 335 x 330 mm - 9.8 kg

• finishing: *WHITE high gloss*



30



### BASSO 850

active subwoofer  
275 mm speaker diameter  
twin reflex port  
AB-Class amplifier  
150 watt nominal power  
200 watt max power  
27 ÷ 180 hertz frequency response  
40 ÷ 180 hertz crossover frequency  
220 ÷ 240 volt power supply  
250 watt max power consumption  
<0.5 watt stand-by consumption  
310 x 335 x 440 mm - 12.2 kg

• finishing: BLACK matt vinyl



### BASSO 830

active subwoofer  
220 mm speaker diameter  
twin reflex port  
AB-Class amplifier  
75 watt nominal power  
125 watt max power  
36 ÷ 180 hertz frequency response  
40 ÷ 180 hertz crossover frequency  
220 ÷ 240 volt power supply  
125 watt max power consumption  
<0.5 watt stand-by consumption  
250 x 305 x 420 mm - 8.8 kg

• finishing: BLACK matt vinyl



31



## MIO SUB

active subwoofer  
178 mm speaker diameter  
twin reflex port  
AB-Class amplifier  
50 watt nominal power  
80 watt max power  
40 ÷ 180 hertz frequency response  
40 ÷ 180 hertz crossover frequency  
220 ÷ 240 volt power supply  
80 watt max power consumption  
<0.5 watt stand-by consumption  
230 x 255 x 230 mm - 5.9 kg

• finishing: BLACK matt vinyl

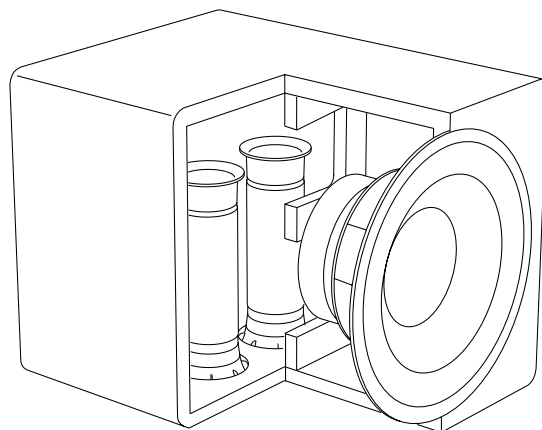

Il doppio condotto reflex riduce al minimo la turbolenza del flusso d'aria.

*The twin-reflex tube minimizes the airflow turbulence.*

Luna è un compatto diffusore acustico due vie, particolarmente adatto per la sonorizzazione di ambienti, anche di grandi dimensioni. Il grande cono in mica-polipropilene e l'elevata efficienza del tweeter consentono il raggiungimento della sua elevata dinamica.

*Luna is a two way compact loudspeaker, particularly suitable for sound distribution. The large mica-polypropylene cone and the high sensitivity of the tweeter make possible to reach its high dynamics.*

# LUNA

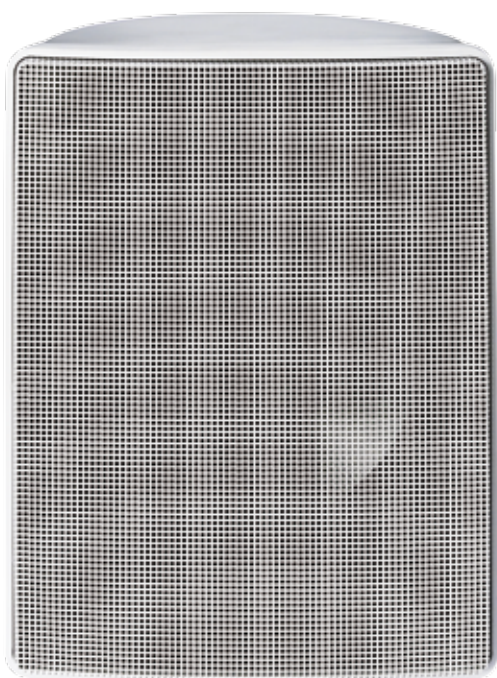

Il box è realizzato con materiali resistenti all'umidità ed ai raggi del sole.

*The box materials are humidity and sun rays resistant.*

## LUNA

book-shelf loudspeaker  
2-way, closed box  
20 ÷ 80 watt suggested amplifier  
4 ÷ 8 ohm amplifier load impedance  
58 ÷ 22000 hertz response  
92 dB (2.83 V / 1 m) sensitivity  
166 mm woofer  
20 mm dome tweeter  
4000 hertz crossover  
180 x 240 x 160 mm - 2.3 kg

• aluminium grille • UV rays protection

• finishing: WHITE

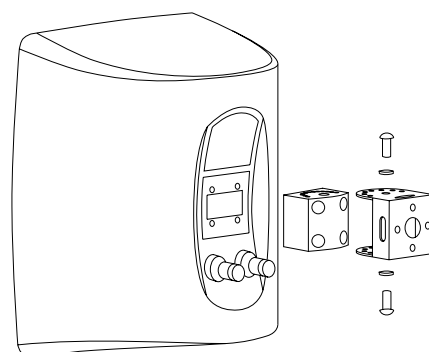

La staffa in dotazione permette il fissaggio a parete con diverse angolazioni.

*The supplied bracket makes the on-wall clamping easy with several angles.*



# NANO



La staffa in dotazione permette il fissaggio a parete con diverse angolazioni.

*The supplied bracket makes the on-wall clamping easy with several angles.*

33

Diffusore acustico molto compatto, adatto per piccoli impianti hi-fi e home cinema, effetti surround e sonorizzazione di ambienti. Nano è disponibile bianco ghiaccio o nero opaco.

*Very compact loudspeaker suitable to build small hi-fi stereo and home cinema systems, surround effects and sound distribution. Nano is available in ice white or matt black.*



## NANO.2

book-shelf loudspeaker  
2-way, bass-reflex  
20 ÷ 60 watt suggested amplifier  
4 ÷ 8 ohm amplifier load impedance  
65 ÷ 22000 hertz response  
90 dB (2.83 V / 1 m) sensitivity  
100 mm woofer  
24 mm ring dome tweeter  
5000 hertz crossover  
120 x 190 x 122 mm - 1.6 kg

• *shielded loudspeakers*

• *finishing: BLACK / WHITE*

I diffusori da incasso sono adatti alla realizzazione di impianti hi-fi stereo e home cinema, effetti surround e sonorizzazione di ambienti. Possono essere montati sia su pareti in muratura che su tramezzi o controsoffitti in cartongesso, senza l'uso di ulteriori accessori.

*The in-wall speakers are suitable for hi-fi stereo and home cinema systems, surround effects and sound distribution. They can be easily installed on brick walls or directly on plasterboard walls without using additional accessories.*

## IN - WALL

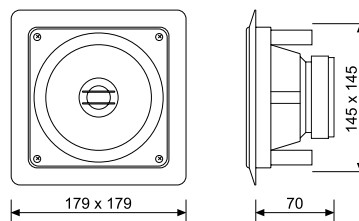
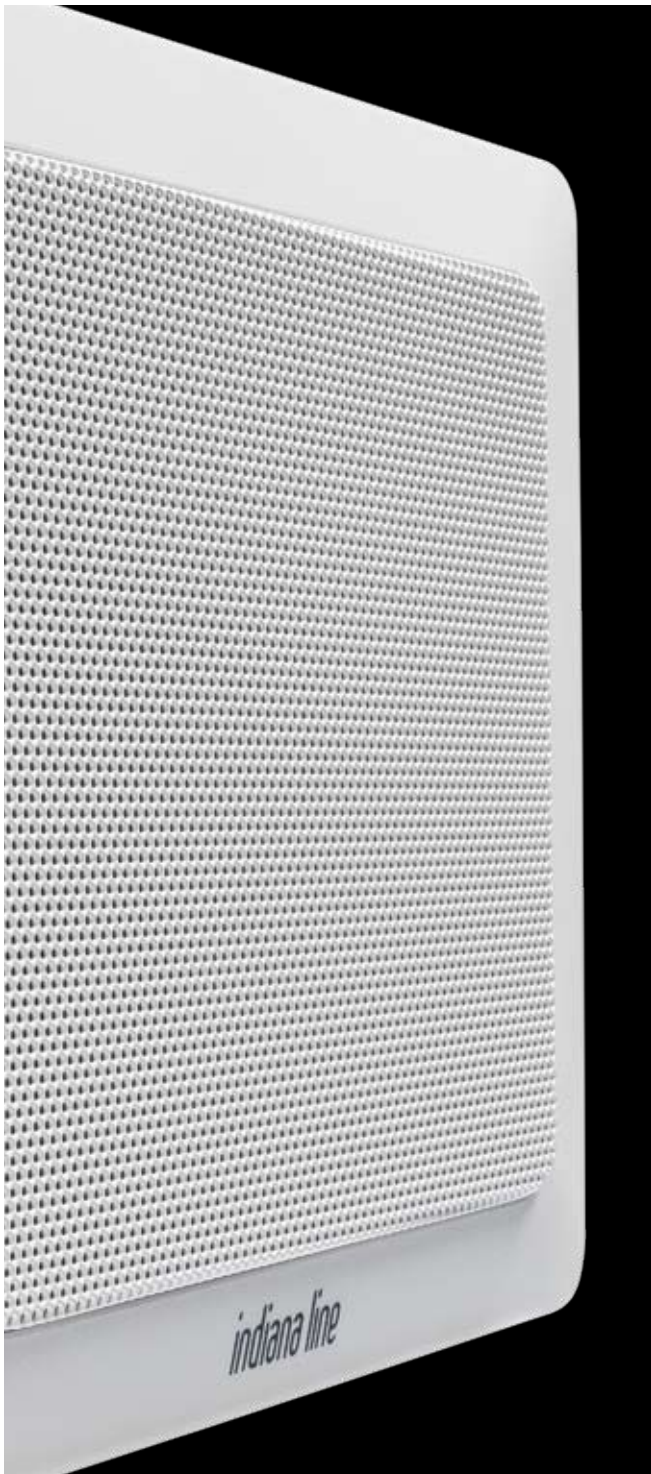

### SQ 250

2-way, in-wall loudspeaker  
20 ÷ 60 watt suggested amplifier  
4 ÷ 8 ohm amplifier load impedance  
70 ÷ 22000 hertz response  
90 dB (2.83 V / 1 m) sensitivity  
130 mm woofer  
20 mm dome tweeter  
3800 hertz crossover

Tesi Q è realizzato con gli stessi componenti di Tesi 260, di cui mantiene lo stesso timbro. Può essere installato direttamente su pareti in cartongesso; per l'installazione su pareti di mattoni, si consiglia di utilizzare il box in legno fornito in dotazione.

*Tesi Q is made with the same components of Tesi 260, of which it keeps the same tonal balance. It can be installed directly on plasterboard walls; for installation on brick walls, we recommend using the back wood box supplied.*

35



## TESI Q

2-way, in-wall loudspeaker  
 30 ÷ 120 watt suggested amplifier  
 4 ÷ 8 ohm amplifier load impedance  
 65 ÷ 22000 hertz response  
 90 dB (2.83 V / 1 m) sensitivity  
 160 mm woofer  
 26 mm dome tweeter  
 2500 hertz crossover

• back wood box supplied

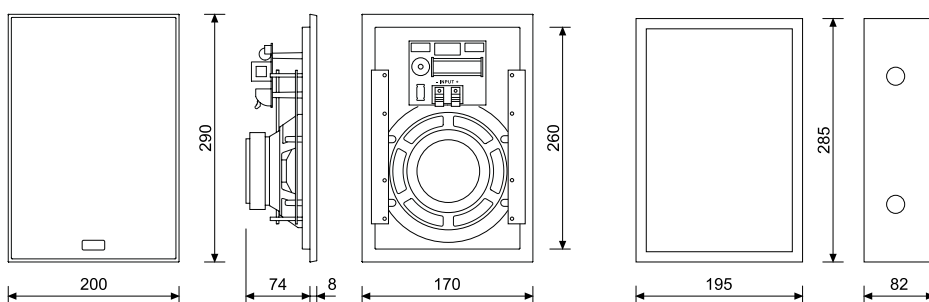

36

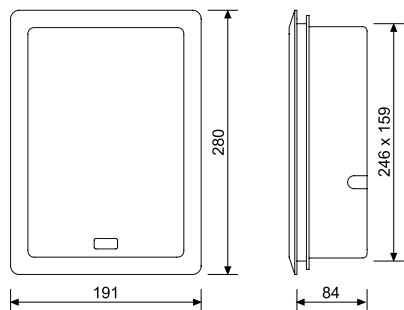

### SQ 205

2-way, in-wall loudspeaker  
20 ÷ 60 watt suggested amplifier  
4 ÷ 8 ohm amplifier load impedance  
75 ÷ 22000 hertz response  
90 dB (2.83 V / 1 m) sensitivity  
130 mm woofer  
26 mm dome tweeter  
3400 hertz crossover

• back plastic box supplied



Con il controllo di volume RV 52 è possibile collegare più coppie di diffusori acustici ad un solo amplificatore e regolare il livello di ogni coppia in modo indipendente.

*Using the volume control RV 52 you can connect more pairs of speakers to a single amplifier and adjust the level for each pair independently.*

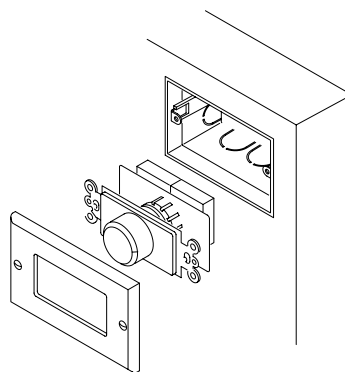

### RV 52

stereo sound level control  
25 + 25 watt nominal power  
4 ÷ 8 ohm amplifier load impedance  
25 ÷ 20000 hertz response  
9 + 1 (off) steps  
115 x 70 x 50 mm

• adatto per scatola da incasso tipo 503

I diffusori da soffitto sono adatti alla sonorizzazione di locali di ogni dimensione. Notevole la loro facilità di montaggio su soffitti e pareti in cartongesso, senza l'uso di ulteriori accessori.

*The ceiling loudspeakers are suitable for sound distribution on all size rooms. They can be easily installed on ceilings or walls in plasterboard, without using additional accessories.*

## IN-CEILING

37

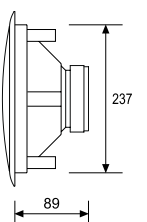
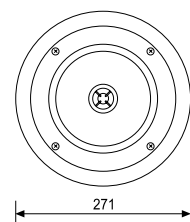
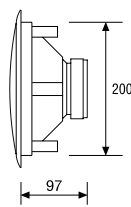
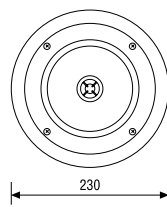

### RD 260

2-way, in-ceiling loudspeaker  
 20 ÷ 60 watt suggested amplifier  
 4 ÷ 8 ohm amplifier load impedance  
 50 ÷ 22000 hertz response  
 92 dB (2.83 V / 1 m) sensitivity  
 165 mm woofer  
 24 mm ring tweeter  
 4000 hertz crossover

### RD 280

2-way, in-ceiling loudspeaker  
 20 ÷ 70 watt suggested amplifier  
 4 ÷ 8 ohm amplifier load impedance  
 48 ÷ 22000 hertz response  
 93 dB (2.83 V / 1 m) sensitivity  
 210 mm woofer  
 24 mm ring tweeter  
 4000 hertz crossover

2016



- 4 PURO
- 8 DIVA
- 14 TESI
- 20 NOTA
- 24 DJ
- 26 ZERO
- 28 BASSO
- 32 LUNA
- 33 NANO
- 34 IN-WALL
- 37 IN-CEILING

indiana line

WWW.INDIANALINE.IT



Indiana Line is a brand of  
Coral Electronic srl  
10098 Rivoli - Torino - Italy  
corso Allamano 74  
info@coralelectronic.com  
www.indianaline.it

Ci riserviamo il diritto di modificazioni senza preavviso.  
Decliniamo ogni responsabilità per eventuali errori o imprecisioni.

*We reserve the right to change specifications without notice. We decline every liability for any mistake or inaccuracy of this catalogue.*

2016

indiana line

